



Project \_\_\_\_\_  
 AIA # \_\_\_\_\_ SIS # \_\_\_\_\_  
 Item # \_\_\_\_\_ Quantity \_\_\_\_\_ C.S.I. Section 114000



## PW3S Triple Wide Proof Box



### SPECIFIER STATEMENT

The proofer shall be of stainless steel construction, manufactured in the United States by Baxter Mfg. The unit footprint shall be no wider than 109.0" and have two height options to meet the needs of the site and the project. Built using modular panel construction with cam lock attachment, the proofer shall incorporate foam insulation and gaskets to form a strong, energy efficient enclosure. Nonmetallic interior bumpers shall protect the interior on all sides.

The proofer shall include eye level, digital controls in the door, and a patented air flow system. No ramp is required for this unit. The controls will independently set temperature and humidity for precise proofing control. Four individual count-down timers for products with different time requirements shall be provided. The air flow system will include an internally mounted humidifier. No flush cleaning is required. Although 3 racks wide, the unit must have only two doors, hinged so as to not require a center jamb, giving maximum access to the proofer.

The proofer will bear the following agency approvals: UL for safety and sanitation for the U.S. and Canada.

### STANDARD FEATURES

- + Patented air flow system
- + Easy access heat and humidity system
  - Internally mounted
  - No flushing required
- + Eye-level digital control panel
  - Set heat/humidity system
  - Four independent timers
- + Stainless steel interior and exterior
- + Modular panel construction with cam lock attachment
- + Field assembled – shipped knocked down
- + Open floor – no ramp required
- + 99.5" overall height to match rack oven

### OPTIONS & ACCESSORIES

- Low profile, 94" overall height
- Stainless steel floor – no ramp required
- Interior light
- Prison package
- Upper side trim – 1 or 2 sides

### MODEL CONFIGURATIONS

- 40.5"D**
  - Four Single End or Six Side Racks, or Three Double Racks
- 60.5"D**
  - Eight Single End or Side Load Racks, or Three Double Racks
- 80.5"D**
  - Eleven Single End or Twelve Side Load Racks, or Six Double Racks
- 100.5"D**
  - Twelve Single End or Fifteen Side Load Racks, or Six Double Racks
- 120.5"D**
  - Sixteen Single End or Eighteen Side Load Racks, or Nine Double Racks

**PW3S TRIPLE WIDE PROOF BOX**

Approved by \_\_\_\_\_ Date \_\_\_\_\_ Approved by \_\_\_\_\_ Date \_\_\_\_\_



# PW3S Triple Wide Proof Box

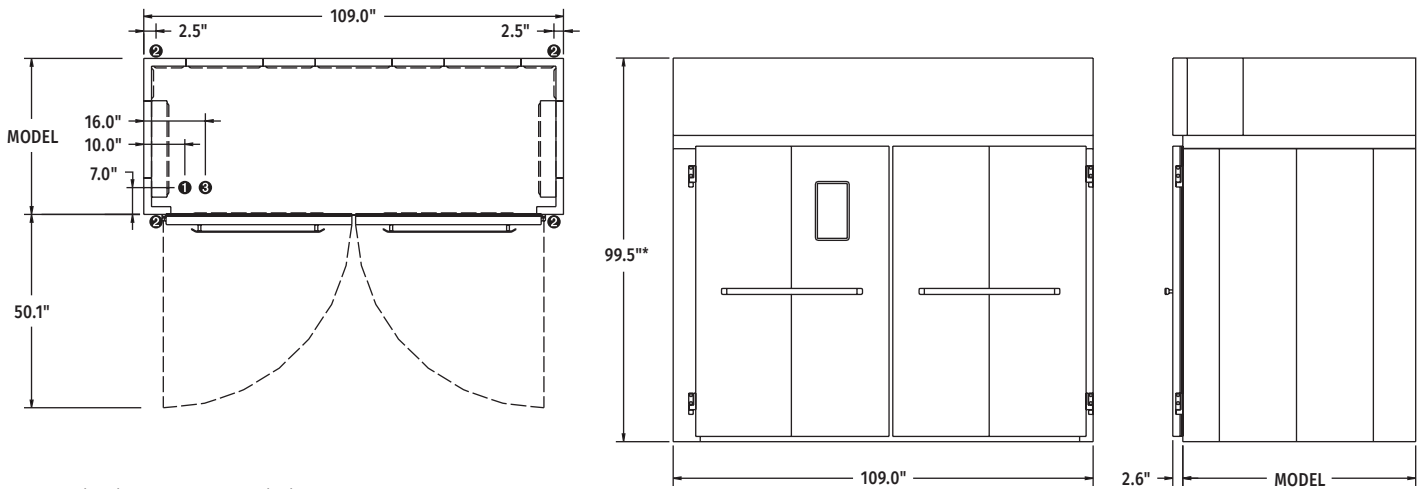

\*94.0" height if low profile front trim is ordered.

**Maximum Rack Height: 74" (188cm)**

PHYSICAL DATA	MODEL 40.5"D	MODEL 60.5"D	MODEL 80.5"D	MODEL 100.5" D	MODEL 120.5"D
<b>Interior Dimensions</b>	37.8"D x 95.0"W x 74.5"H	57.8"D x 95.0"W x 74.5"H	77.8"D x 95.0"W x 74.5"H	97.8"D x 95.0"W x 74.5"H	117.8"D x 95.0"W x 74.5"H
<b>Exterior Dimensions</b>	43.4"D x 109.0"W	63.3"D x 109.0"W	83.3"D x 109.0"W	103.3"D x 109.0"W	123.3"D x 109.0"W
<b>Net Door Opening Height</b>	74.5"	74.5"	74.5"	74.5"	74.5"
<b>Net Door Opening Width</b>	94.7"	94.7"	94.7"	94.7"	94.7"
<b>Power Input with Neutral <sup>A</sup></b>	208-240V/60/3/32-36A	208-240V/60/3/32-36A	208-240V/60/3/34-38A	208-240V/60/3/34-38A	208-240V/60/3/34-38A
<b>Heat Wattage (KW)</b>	6.6-8.8	6.6-8.8	9.9-13.2	9.9-13.2	9.9-13.2
<b>Water Flow Rate (GPM)</b>	1.0	1.0	1.5	1.5	1.5
<b>Maximum Water Usage (GPH)</b>	2.0	2.0	3.0	3.0	3.0

## UTILITIES & NOTES

- ❶ **Water:** ½" FNPT cold water 30-80 psi at 85" (215.9 cm) AFF. Maximum water usage varies by depth. See chart above for specific information.  
**Note:** Water supply must have the proper hardness, pH & chloride concentration. Consult your local water company and/or water conditioner dealer before installation.
  - **Recommended water hardness range:** 2-4 grains per gallon.
  - **Recommended pH range:** 7.0-8.0.
  - **Acceptable range for chloride concentration:** 0-30 ppm.
- ❷ **Drain:** ½" FNPT, front or rear drain at 5" (12.7 cm) AFF. Route to air-gap drain.
- ❸ **Power:** Provide connection(s) at 85" (215.9 cm) AFF. See chart above for specific information.
  - <sup>A</sup> **Neutral wire circuitry** needed to provide 110-120V for control components. A separate line may be run or a transformer will be required if 110-120V is not available.

## INSTALLATION

- Floor should be level within ¼" per foot for proper installation. Slope should not exceed ¼" in all directions under the unit. Proofers without the floor option must be installed on a corrosion resistant and cleanable surface.
- ⓔ **Shipping:** Contact factory for shipping information.
  - Important:**
    - Do not route utilities (wiring, plumbing, etc.) in or under the non-combustible floor beneath the proofer.
    - A minimum of 1" airgap between proofer and oven recommended to ensure proper proofer operation.
    - 10' ceiling height is recommended for proper airflow and service access.